

SIGA-OSCD Intelligent Optical Smoke Detector with CO Sensor Installation Sheet

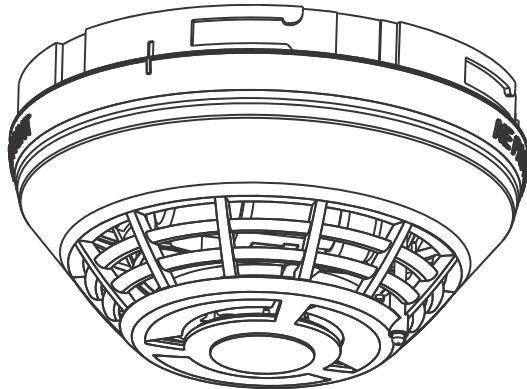

Description

The Signature Series model SIGA-OSCD Intelligent Optical Smoke Detector with CO Sensor is an intelligent device that uses an advanced optical sensing chamber to detect smoke. The detector analyzes data from the sensing chamber to recognize smoke from a fire while ignoring nuisance non-fire sources and whether to initiate an alarm to the Fire Alarm Control Panel. A separate CO sensor is used to detect carbon monoxide from sources of combustion. The detector analyzes the smoke and CO sensors independently to determine whether to initiate a fire alarm, a life safety CO alarm, or both.

LED indicator. The LED indicator (see Figure 1) displays the following states:

- Normal: Green LED indicator flashes, no action.
- Alarm/active: Red LED indicator flashes, evacuate the area.

Sensor end-of-life indicator. The detector signals a "COMMON TRBL ACT" condition on the control panel when the CO sensor reaches its end of life. Pressing the Details button on the control panel displays "END OF LIFE ACT" providing verification that it is an end-of-life trouble of the CO sensor. This trouble remains active until the detector is replaced, even if the panel is reset.

Figure 1: SIGA-OSCD features

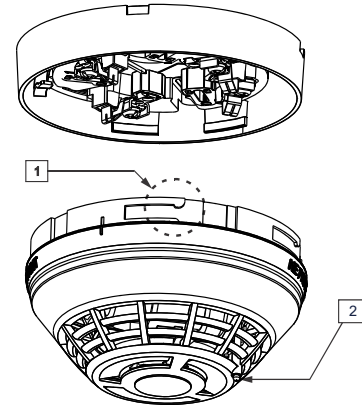

- (1) Self-locking tab
- (2) LED indicator

Installation

Notes

- This detector does not sense fires in areas where smoke cannot reach the detector. Smoke from fires in walls, roofs, or on the opposite side of closed doors may not reach the detector.
- This detector does not detect oxygen levels or flames. Use this device as part of a broad-based life safety program which includes a variety of information sources pertaining to heat and smoke levels, extinguishment systems, visual and audible devices, and other safety measures.
- To ensure proper operation, store the detector within the recommended ranges. Allow the detector to stabilize to room temperature before applying power.
- The dust cover (supplied) must remain on the detector during installation and be removed prior to commissioning and service. The dust cover is not a substitute for removing the detector during new construction or heavy remodeling.
- Do not install detectors until after final construction cleanup (unless otherwise specified by the AHJ).
- Do not use smoke detectors with detector guards unless the combination has been evaluated and found suitable.
- Install per NFPA 72 *National Fire Alarm and Signaling Code*, NFPA 720 *Standard for the Installation of Carbon Monoxide (CO) Detection and Warning Equipment*, and UL 2075 *Standard for Gas and Vapor Detectors and Sensors*.
- Upon completion of the original installation and following any modifications or additions to the system, perform a calibrated sensitivity test per NFPA code. The Signature Series can perform this test and generate a system sensitivity report.

To install the detector:

1. Install and wire the base, as described on the installation sheet supplied with the base.
2. Remove the serial number label from the detector and attach it to the project documentation.
3. Attach the detector to the base by rotating the detector clockwise until it snaps into the locked position.
4. If required by the AHJ or local codes, affix the supplied CO Warning Label (P/N 3303928) in proximity to the detector.



Carbon monoxide alarm procedure

WARNING: The carbon monoxide (CO) alarm indicates the presence of CO, which can kill you. If the alarm signal sounds four times, pauses for five seconds, and then repeats the pattern, follow the steps shown below.

1. Move to fresh air immediately — outdoors or by an open door or window. Check that all persons are accounted for. Do not reenter the premises or move away from the open door or window until emergency services responders have arrived, the premises have been aired out, and your detector remains in normal condition.
2. Call emergency services, the fire department, or 911:

Phone:

Information about carbon monoxide

WARNINGS

- Read these installation instructions in their entirety before proceeding. Leave these instructions with the owner/user of this CO detection equipment.
- This product is intended for use in indoor locations of dwelling units. It is not designed to comply with Occupational Safety and Health Administration (OSHA) commercial or industrial standards.
- The detector only indicates the presence of CO gas at the detector. Carbon monoxide gas may be present in other areas.
- Failure to properly install, test, and maintain a CO detector may cause it to fail, potentially resulting in loss of life.
- Installation of this detector is not a substitute for proper installation, use, and maintenance of fossil fuel-burning appliances, including appropriate ventilation and exhaust systems.
- To reduce the risk of CO poisoning, test the detector operation when not in use for 10 days or more.
- This detector does not operate without electrical power. As fires frequently cause power interruption, discuss further safeguards with the authority having jurisdiction (AHJ).
- Do not paint the detector.

Notes

- Regulatory code may require that the system generate a three-pulse temporal code (TC3) for fire alarms and a four-pulse temporal code (TC4) for CO alarms.
- The CO sensor is calibrated at the factory. CO sensitivity is set to conform to UL 2034 requirements and cannot be changed by the user. See "Regulatory information" on page 4 for specific sensitivity values.
- Connect this detector only to a UL Listed control panel capable of differentiating between alarm signals (fire, burglary, CO, etc.) and providing distinct identification for each.
- To reduce the likelihood of nuisance alarms, ventilate accommodation spaces when using household cleaning supplies or similar contaminants. If a detector has been exposed to such contaminants, test it promptly afterwards.

Symptoms of CO poisoning

The following symptoms related to CO poisoning should be discussed with all occupants of the protected site.

Mild exposure: Slight headache, nausea, vomiting, fatigue, runny nose, sore eyes (often described as "flu-like" symptoms).

Medium exposure: Severe throbbing headache, dizziness, drowsiness, confusion, fast heart rate.

Extreme exposure: Unconsciousness, brain damage, convulsions, cardiorespiratory failure, death.

Many cases of reported CO poisoning indicate that while victims are aware they are not well, they become so disoriented that they are unable to save themselves by either exiting the building or calling for assistance. Young children and pets may be the first affected.

CO sources

The CO sensor in this detector is designed to detect carbon monoxide gas from *any* source of combustion. It is not intended to detect fire, smoke, or any other gas. Potential CO sources include fuel-fired appliances (e.g., space heater, furnace, water heater, range, oven, clothes dryer); other sources of combustion (e.g., kerosene-burning stove or heater, or gas log fireplace); or internal combustion engines.

In addition, excessive exhaust spillage or reverse venting of fuel-burning appliances can produce dangerous transient levels of CO. This can be caused by external conditions:

- Wind direction, velocity, or a combination of both, including high gusts of wind or insufficient draft in vent pipes
- Temperature inversions that can trap exhaust gases near the ground
- Negative pressure differential resulting from the use of exhaust fans
- Simultaneous operation of several fuel-burning appliances competing for limited internal air
- Vent pipe connections vibrating loose from dryers, furnaces, or water heaters
- Obstructions in vent pipes or unconventional vent pipe designs which can amplify the above situations
- Poorly designed or maintained chimneys and/or vents
- Extended operation of unvented fossil fuel-burning devices (range, oven, fireplace, etc.)
- Idling cars in an open or closed attached garage, or near the premises

General limitations of CO detectors

This detector is designed to protect individuals from the acute effects of CO exposure. It will not fully safeguard individuals with specific medical conditions. People with special medical problems should consider using specialized detection devices with less than 30 ppm (parts per million) alarming capabilities. If in doubt, consult a medical practitioner.

If the detector is in trouble or at the end of its life, it may not sense CO and cannot be relied upon to monitor CO levels. Replace the detector every ten years from the date of manufacture or when the control panel indicates a sensor end-of-life condition, whichever comes first.

A detector installed outside a bedroom may not awaken a sleeper. Normal noise due to stereos, television, etc. may also prevent the detector from being heard if distance or closed or partly closed doors muffle the sounder. This unit is not designed for the hearing impaired.

CO detectors are not a substitute for life safety. Though these detectors will warn against increasing CO levels, we do not warrant or imply in any way that they will protect lives from CO poisoning. They should only be considered as an integral part of a comprehensive safety program.

Detector locations

Selecting a suitable location is critical to the operation of CO detectors. Figure 2 shows appropriate detector locations.

Verify the detector is installed in accordance with all applicable governing laws, codes, or standards. For combination detectors, follow the spacing requirements for each sensor. Refer to the control panel's application bulletin for the sensor spacing requirements.

The recommended CO detector locations are:

- Outside each separate sleeping area in the immediate vicinity of the bedrooms (including areas such as hotel rooms and dorm rooms)
- On every occupiable level of a dwelling unit, including basements, but excluding attics and crawl spaces
- Centrally located on every habitable level of the building and in every HVAC zone based on an engineering evaluation considering potential sources and migration of carbon monoxide
- On the ceiling in the same room as permanently installed fuel-burning appliances
- In any area required by local building codes, legislation, or the AHJ
- In a suitable environment per the detector specifications (see "Specifications" on page 4 for details)
- On a firm, permanent surface

Do not install the CO detector:

- Within 5 ft. (1.5 m) of any cooking appliance
- Within 10 ft. (3 m) of a fuel-burning appliance
- Near air conditioners, heating registers, or any other ventilation source that may interfere with CO gas entering the detector
- Where furniture or draperies may obstruct the airflow
- In a recessed area

Figure 2: Recommended CO detector locations



▲ Recommended CO detector location

Testing

Before testing, notify the proper authorities that the fire alarm system is undergoing maintenance and will be temporarily out of service.

Note: If the CO sensor is programmed as an alarm point, it must comply with the requirements of NFPA 720.

To perform an initial installation test:

1. Visually inspect each detector and verify that it is installed in the correct location. Make sure that factors not apparent in the plans do not adversely affect the detector.
2. Remove the detector from its base and verify that the proper detector address, trouble signals, and messages are reported.
3. If wired for Class A operation, verify that the detector continues to operate first with SLC_IN disconnected, and then with SLC_OUT disconnected. (Refer to the installation sheet for the base.)
4. Place a momentary ground fault on the SLC circuit to verify operation of the ground fault detection circuitry.
5. Run a system detector sensitivity report on all detectors and verify that readings fall within acceptable limits.
6. Perform a sensor function test, as described below.

To perform CO sensor function tests:

1. Use the fire alarm control panel to put the detector into accelerated response mode. (Refer to the panel technical reference manual for instructions.)
2. Activate the CO sensor using SDI LLC model Solo C6 CO aerosol spray without covering the head, or using the Testfire detector tester per the manufacturer's instructions.

To perform smoke sensor function tests:

1. If desired, use the fire alarm control panel to put the detector or zone into a service group for testing. (Refer to the panel technical reference manual for instructions.)
2. Activate the smoke sensor using No Climb Products model Smoke Centurion/M8, FireTech Smoke or Smoke Sabre smoke aerosol spray, a smoke generator, or the Testfire detector tester per the manufacturer's instructions.

Maintenance

To ensure proper operation, plan maintenance (regular or selected) of the detector in accordance with the AHJ and all applicable governing laws, codes, or standards. Refer to NFPA 72 *National Fire Alarm and Signaling Code*, NFPA 720 *Standard for the Installation of Carbon Monoxide (CO) Detection and Warning Equipment*,

Refer to application bulletin P/N 3102625-EN for additional information and cleaning instructions.

CO sensor. The CO sensor has a 10 years life from the date of manufacture or when the control panel indicates a sensor end-of-life condition, whichever comes first.

Specifications

Operating voltage	15.20 to 19.95 VDC
Current	
Normal operating	32 μ A
Alarm	45 μ A
Vibration level	10 to 35 Hz, with an amplitude of 0.01 in.
Air velocity [1]	0 to 4,000 ft./min (0 to 20.32 m/s)
Wall mount distance from ceiling	12 in. (305 mm) max.
Compatible bases	
Standard	SIGA-SB, SIGA-SB4
Relay	SIGA-RB, SIGA-RB4
Isolator	SIGA-IB, SIGA-IB4
Audible	SIGA-AB4G, SIGA-AB4GT SIGA-AB4G-LF
Compatible detector testers	Testifire 2000
Operating environment	
Temperature	32 to 120°F (0 to 49°C)
Relative humidity	0 to 90% noncondensing
Storage temperature	-4 to 140°F (-20 to 60°C)
Environmental compensation	Automatic

[1] For duct installation, use a SIGA-DMP duct detector mounting plate and install per P/N 387053-EN.

Regulatory information

UL smoke sensitivity range	0.5 to 4.36 %/ft. (1.63 to 13.62 %/m) obscuration
UL CO alarm level	70 ppm 60 to 240 minutes [1] 150 ppm 10 to 50 minutes [1] 400 ppm 4 to 15 minutes [1]
UL CO False alarm level	30 ppm 30 days[1] 70 ppm 60 minutes[1]
North American standards	UL 268-7, UL 2075 Note: This detector has been evaluated to the CO alarm sensitivity limits of UL 2034.
FCC compliance	This device complies with part 15 of the FCC Rules. Operation is subject to the following two conditions: (1) This device may not cause harmful interference, and (2) this device must accept any interference received, including interference that may cause undesired operation.

[1] Sensitivity per UL 2034

Contact information

For contact information, see www.edwardsfiresafety.com.